

**TM 11-6665-245-12**

---

**TECHNICAL MANUAL**

**OPERATOR AND ORGANIZATIONAL  
MAINTENANCE MANUAL**

**RADIAC SET**

**AN/PDR-56F**

**(NSN 6665-00-211-6895)**

This copy is a reprint which includes current pages from Changes 1 and 2.

---

**HEADQUARTERS, DEPARTMENT OF THE ARMY**

**5 DECEMBER 1980**

## **WARNING**

The check source used in this equipment contains Thorium (a radioactive metal). Thorium is a hazardous material. Injury or disease may result if the Thorium check source is not handled properly.

Observe the following precautions:

Do not scratch or abrade the check source in any way to produce small particles. If small particles are produced, use extreme caution to avoid inhalation—Do not allow particles to enter the body, through open cut or mouth. Wash any area suspected of being contaminated with Thorium with luke warm water and a non-abrasive soap. Contact qualified medical personnel and the local Radiological Protection Officer (RPO) immediately if you are exposed to check source material.

Use extreme care not to touch, scratch, or break or remove the surface of the check source while handling them.

Should the check source become dislodged from the radiac set, return the radiac set and check source for maintenance.

Never place a dislodged check source in your pocket.

Do not clean check source with abrasives.

Refer to TB 43-0116, TB 43-0122, and AR 385-11 for instructions on first aid, safe handling, storage and disposal of radioactive material.

CHANGE

HEADQUARTERS  
DEPARTMENT OF THE ARMY  
WASHINGTON, DC, 15 January 1986

NO. 2

OPERATOR'S AND ORGANIZATIONAL  
MAINTENANCE MANUAL  
RADIAC SET AN/PDR-56F  
(NSN 6665-01-113-9530)

TM 11-6665-245-12, 5 December 1980, is changed as follows:

1. Remove and insert pages as indicated below.
2. New or changed material is indicated by a vertical bar in the margin of the page,
3. Added or revised illustrations are indicated by a vertical bar adjacent to the figure caption.

*Remove Pages*

i and ii .....  
1-1 thru 1-4 .....  
2-1 thru 2-5 .....  
3-1 .....  
A-1 .....  
B-1 thru B-3 .....  
C-3 thru C-6 .....

*Insert Pages*

i and ii .....  
1-1 thru 1-4 .....  
2-1 thru 2-8 .....  
3-1/(3-2 blank) .....  
A-1/(A-2 blank) .....  
B-1 thru B-3/(B-4 blank) .....  
C-3 thru C-6 .....

4. File this change sheet in front of the publication.

By Order of the Secretary of the Army:

JOHN A. WICKHAM JR.  
*General, United States Army*  
*Chief of Staff*

Official:

MILDRED E. HEDBERG  
*Brigadier General, United States Army*  
*The Adjutant General*

DISTRIBUTION:

To be distributed in accordance with DA Form 12-36 literature requirements for AN/PDR-56F.

CHANGE }  
No. 1 }

HEADQUARTERS  
DEPARTMENT OF THE ARMY  
WASHINGTON, DC, 28 January 1983 ■

**Operator and Organizational  
Maintenance Manual  
RADIAC SET AN/PDR-56F  
(NSN 6665-01-113-9530)**

TM 11-6665-245-12, 5 December 1980, is changed as follows:

1. The title of the manual is changed as shown above.
2. New or changed material is indicated by a vertical bar in the margin of the page.
3. Remove and insert pages as indicated below.

<i>Remove</i>	<i>Insert</i>
i and ii .....	i and ii
1-1 and 1-2 .....	1-1 and 1-2
2-1 and 2-2 .....	2-1 and 2-2
3-1 .....	3-1
4-1 and 4-2 .....	4-1 and 4-2
A-1 .....	A-1
C-3 through C-6 .....	C-3 through C-5/(C-6 blank)

4. File this change sheet in front of the publication for reference purposes.

By Order of the Secretary of the Army:

Official:

E. C. MEYER  
*General, United States Army*  
*Chief of Staff*

ROBERT M. JOYCE  
*Major General, United States Army*  
*The Adjutant General*

Distribution:

To redistributed in accordance with Special Mailing List.

**OPERATOR'S AND ORGANIZATIONAL MAINTENANCE MANUAL  
RADIAC SET AN/PDR-56F  
(NSN 6665-01-113-9530)**

**REPORTING ERRORS AND RECOMMENDING IMPROVEMENTS**

You can help improve this manual. If you find any mistakes or if you know of a way to improve the procedures, please let us know. Mail your letter, DA Form 2028 (Recommended Changes to Publications and Blank Forms) or DA Form 2028-2 located in back of this manual direct to Commander, US Army Communications-Electronics Command and Fort Monmouth, ATTN: AMSEL-ME-MP, Fort Monmouth, NJ 07703-5007.

In either case, a reply will be furnished direct to you.

**TABLE OF CONTENTS**

		Paragraph	Page
CHAPTER	1. INTRODUCTION		
Section	I. General		
	Scope .....	1-1	1-1
	Consolidated Index of Army Publications and Blank Forms .....	1-2	1-1
	Maintenance Forms, Records and Reports .....	1-3	1-1
	Administrative Storage .....	1-4	1-1
	Reporting Equipment improvement Recommendations (EIR) .....	1-5	1-1
	Hand Receipt .....	1-6	1-1
	Destruction of Army Materiel to Prevent Enemy Use .....	1-7	1-1
	Calibration .....	1-8	1-1
	II. Description and Data		
	Purpose and Use .....	1-9	1-1
	Description .....	1-10	1-1
	Tabulated Data .....	1-11	1-2
CHAPTER	2. OPERATING INSTRUCTIONS		
	Operator Controls .....	2-1	2-1
	Initial Procedures .....	2-2	2-2
	Monitoring Terrain, Supplies and Equipment .....	2-3	2-2
	Monitoring Personnel .....	2-4	2-3
	Equipment Shutdown .....	2-5	2-4
CHAPTER	3. OPERATOR MAINTENANCE INSTRUCTIONS		
	Scope of Maintenance .....	3-1	3-1
	Tools, Materials and Equipment Required for Maintenance .....	3-2	3-1
	Routine Services .....	3-3	3-1
	Operator Preventive Maintenance Checks and Services (PMCS) .....	3-4	3-1
	Cleaning .....	3-5	3-1
	Troubleshooting .....	3-6	3-1

**TABLE OF CONTENTS - Continued**

		Paragraph	Page
CHAPTER	4. ORGANIZATIONAL MAINTENANCE INSTRUCTIONS		
Section	I. Tools and Equipment		
	Tools and Equipment Required . . . . .	4-1	4-1
	Materials Required for Maintenance . . . . .	4-2	4-1
	II. Repainting and Refinishing Instructions		
	Preparation for Painting . . . . .	4-3	4-1
	Priming . . . . .	4-4	4-1
	Touchup Painting . . . . .	4-5	4-1
	III. Troubleshooting		
	General Troubleshooting Instructions . . . . .	4-6	4-1
	Troubleshooting by Visual inspection . . . . .	4-7	4-1
	IV. Maintenance of the Radiac Set		
	Maintenance of the Radiacmeter . . . . .	4-8	4-2
	Preparation for Storage or Shipment . . . . .	4-9	4-2
APPENDIX	A. REFERENCES . . . . .		A-1
Section	B. COMPONENTS OF END ITEM LIST . . . . .		B-1
	I. Introduction . . . . .		B-1
	II. Integral Components of End Item . . . . .		B-3
APPENDIX	C. MAINTENANCE ALLOCATION		
Section	I. Introduction . . . . .		C-1
	II. Maintenance Allocation Chart . . . . .		C-3
	III. Tool and Test Equipment Requirements . . . . .		C-5
	IV. Remarks . . . . .		C-6
APPENDIX	D. EXPENDABLE SUPPLIES AND MATERIALS LIST		
Section	I. Introduction . . . . .		D-1
	II. Expendable Supplies and Materials List . . . . .		D-3

**LIST OF TABLES**

Table	Title	Page
1-1	Tabulated Data . . . . .	1-2
2-1	Operator's Controls and Indicators . . . . .	2-1
4-1	Troubleshooting Chart . . . . .	4-1

**LIST OF FIGURES**

Figure	Title	Page
1-1	Radiac Set, AN/PDR-56F Components . . . . .	1-3
1-2	Radiacmeter IM-160F/PDR-56 . . . . .	1-4
1-3	Case, Radiac Set CY-7375/PDR-56F . . . . .	1-5
2-1	Operator's Controls and Indicators . . . . .	2-4
2-2	Radiac Probe DT-224B/PDR-56 Positioned Over Check Source . . . . .	2-5
2-3	AN/PDR-56F with X-Ray Probe, DT-590A/PDR-56 . . . . .	2-6
2-4	X-Ray Probe DT-590A/PDR-56 Positioned Over Check Source . . . . .	2-7
2-5	Aux Probe installed on Main Probe Handle . . . . .	2-8
4-1	Battery Compartment Cover, Exploded View . . . . .	4-3
B-1	Components of Radiac Set . . . . .	B-2

# CHAPTER 1 INTRODUCTION

## Section I. GENERAL

### 1-1. Scope

This manual contains instructions for operator and organizational maintenance for Radiac Set AN/PDR-56F (radiac set). It includes instructions for installing, operating and maintaining the equipment. It also lists tools, materials and test equipment for operator and organizational maintenance.

### 1-2. Consolidated Index of Army Publications and Blank Forms

Refer to the latest issue of DA Pam 310-1 to determine whether there are new editions, changes or additional publications pertaining to the equipment.

### 1-3. Maintenance Forms, Records and Reports

a. *Reports of Maintenance and Unsatisfactory Equipment.* Department of the Army forms and procedures used for equipment maintenance will be those prescribed by DA Pam 738-750 as contained in Maintenance Management Update.

b. *Report of Packaging and Handling Deficiencies.* Fill out and forward SF 364 (Report of Discrepancy (ROD)) as prescribed in AR 735-11-2/DLAR 4140.55/NAVMATINST 4355.73A/AFR 400-54/MCO 4430.F.

c. *Discrepancy in Shipment Report.* Fill out and forward Discrepancy in Shipment Report (DISREP) (SF361) as prescribed in AR 55-38/NAVSUPINST 4610.33C/AFR 75-18/MCO P4610.19D/DLAR 4500.15.

### 1-4. Administrative Storage

Administrative Storage of Equipment issued to and used by Army activities will have preventive maintenance performed in accordance with the PMCS charts before storing. When removing the

equipment from administrative storage, the PMCS should be performed to assure operational readiness. Disassembly and repacking of equipment for shipment or limited storage are covered in paragraph 4-9.

### 1-5. Reporting Equipment Improvement Recommendations (EIR)

If your Radiac Set AN/PDR-56F needs improvement, let us know. Send us an EIR. You, the user, are the only one who can tell us what you don't like about your equipment. Let us know why you don't like the design. Put it on an SF 368 (Quality Deficiency Report). Mail it to Commander, US Army Communications-Electronics Command and Fort Monmouth, ATTN: AMSEL-ME-MP, Fort Monmouth, NJ 07703-5007. We'll send you a reply.

### 1-6. Hand Receipt

This manual has a companion document with a TM number followed by "HR" (which stands for Hand Receipt). The TM 11-6665-245-12-HR consists of preprinted hand receipts (DA Form 2062) that list end item related equipment (i.e., COEI, BII and AAL) you must account for. As an aid to property accountability, additional HR manuals may be requisitioned from the US Army Adjutant General Publications Center, Baltimore, MD, in accordance with the procedures in Chapter 3, AR 310-2 and DA Pam 310-10.

### 1-7. Destruction of Army Materiel to Prevent Enemy Use

Destruction of Army Electronics materiel to prevent enemy use shall be in accordance with TM 750-244-2.

### 1-8. Calibration

Calibration procedure for Radiac Set, AN/PDR-56F is contained in TM 11-6665-245-34.

## Section II. DESCRIPTION AND DATA

### 1-9. Purpose and Use

The Radiac Set AN/PDR-56F is a portable, battery operated scintillation type instrument for field use in the detection and measurement of alpha radiation and low energy gamma radiation. It is

used to monitor terrain, personnel and equipment for alpha and gamma radiation contamination.

### 1-10. Description

The Radiac Set AN/PDR-56F is comprised of the components shown in Figure 1-1. The components are described below:



a. Radiacmeter IM-160F/PDR-56 is composed of a two piece, cast metal box which has a carrying handle attached to the panel which forms the top of the box. The panel is used to mount all the operating controls, the instrument meter, cable connectors, and a plate used to hold in two batteries. The rest of the box forms a cover for the internal components which are attached to the inside of the top panel. The bottom of the box (Figure 1-2) has a white plastic sheet glued to it. The plastic sheet contains a small piece of thorium in its center. The thorium is used as check source for the radiacmeter.

b. Probe, Radiac DT-224B/PDR-56 (main probe) is a metal box with a handle extended above it so that it can be fitted together with the radiacmeter (Figure 1-1). The handle of the main probe fits inside the handle of the radiacmeter and they are fastened together with a captive screw in the radiacmeter handle. The bottom plate of the main probe (Figure 1-2) has six slots cut into it to form a window area. The window area is covered on the inside with a very thin plastic and foil sheet (light barrier) which makes the main probe light tight but allows for the entry of alpha radiation. When the main probe is not in use, a plastic window cover must be placed over the window area to protect the light barrier. The main probe and the radiacmeter are connected electrically by a short coiled cable.

c. Probe, Radiac DT-228A/PDR-56 (aux probe) is a metal housing which is designed to fit onto the main probe for use in detecting alpha contamination when the main probe would be too bulky. In this case, the main probe is reassembled on it. The aux probe also contains a window area and a light barrier. The light barrier of the aux probe contains a wire screen to protect it from sharp objects. It must also be protected by the plastic aux probe cover when not in use. The plastic cap in the end of the aux probe is a dust and dirt cover.

d. Probe, Radiac DT-590A/PDR-56F (x-ray probe) is a metal cylindrical housing which is designed to be attached to the coil cord cable in place of the main probe for use in detecting low energy gamma radiation (areas contaminated by Plutonium-239 material), In this case, the main probe is disconnected and removed from the radiacmeter and the probe handle is connected to the x-ray probe. The retractile cable is then connected to the x-ray probe. The extension handle may be connected to permit use of the probe in the standing position or to monitor overhead

areas. The x-ray probe contains a wire screen to protect the scintillation crystal assembly from sharp objects.

e. Case, Radiac Set CY-7375/PDR-56F (storage case) is made of sheet steel, has a hinged cover, a carrying handle, and two cover latches. The inside of the storage case (Figure 1-3) is separated into compartments for storage of the components of the Radiac Set AN/PDR-56F. Rubber cushioning pads and a gasket (to make the storage case watertight) are cemented to the inside of the storage case.

f. Miscellaneous components such as the Headset, Electrical H-43B/U (headset), Harness ST-123/PDR-18A (carrying strap), and the extension handle are also provided. The extension handle is an assembly of two telescoping aluminum tubes. The length of the extension handle is adjusted by loosening a clamping nut and sliding the two tubes to the length desired and then retightening the clamp nut.

**1-11. Tabulated Data**

The physical, functional, and performance data is listed in Table 1-1.

Table 1-1. Tabulated Data

Weight	25.75 pounds (11.68 kg)
Size	5 in. x 15 in. x 11.375 in. 12.7 cm x 38.1 cm x 28.89 cm
Temperature Limits:	-20 degrees C to + 50 degrees C
Input Power Requirement:	3.0 vdc (two type BA "D" cells)
Radiation Measured:	(Alpha) 3 MeV (and above, up to 10 <sup>6</sup> counts) (Gamma) 10 keV to 60 keV - adjustable
Detection Efficiency:	Greater than 11%
Accuracy:	±20% over upper 80% of 10 <sup>3</sup> counts per minute (cpm) range
Variable Meter Ranges:	10 <sup>3</sup> , 10 <sup>4</sup> , 10 <sup>5</sup> , 10 <sup>6</sup> cpm
Indications:	Meter and Headphone
Detection Area:	Main Probe - 17 cm <sup>2</sup> , Auxiliary Probe - 11 cm <sup>2</sup> : X-Ray Probe - 10 cm <sup>2</sup>
Battery Life Expectancy:	50 hours with continuous use

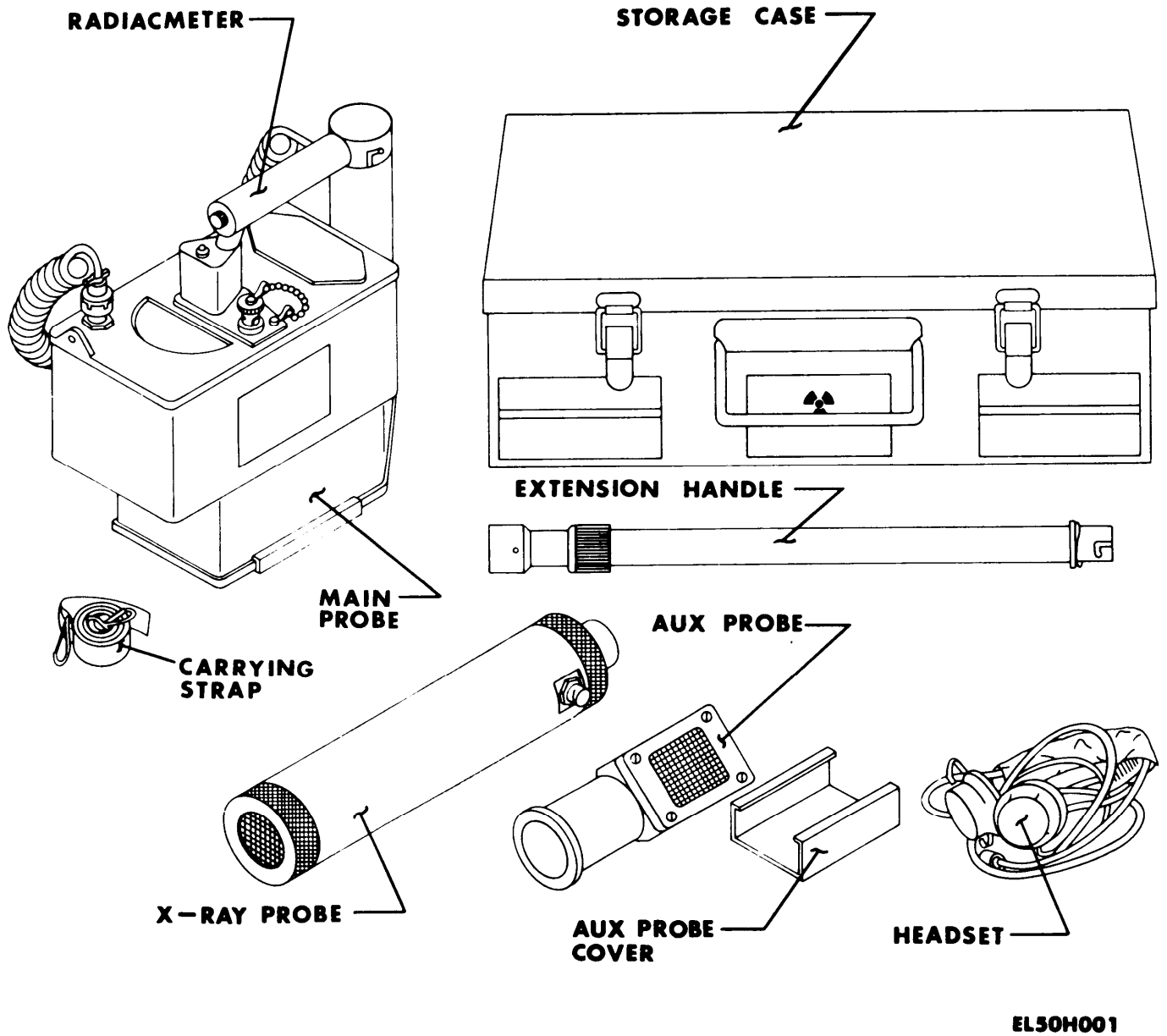
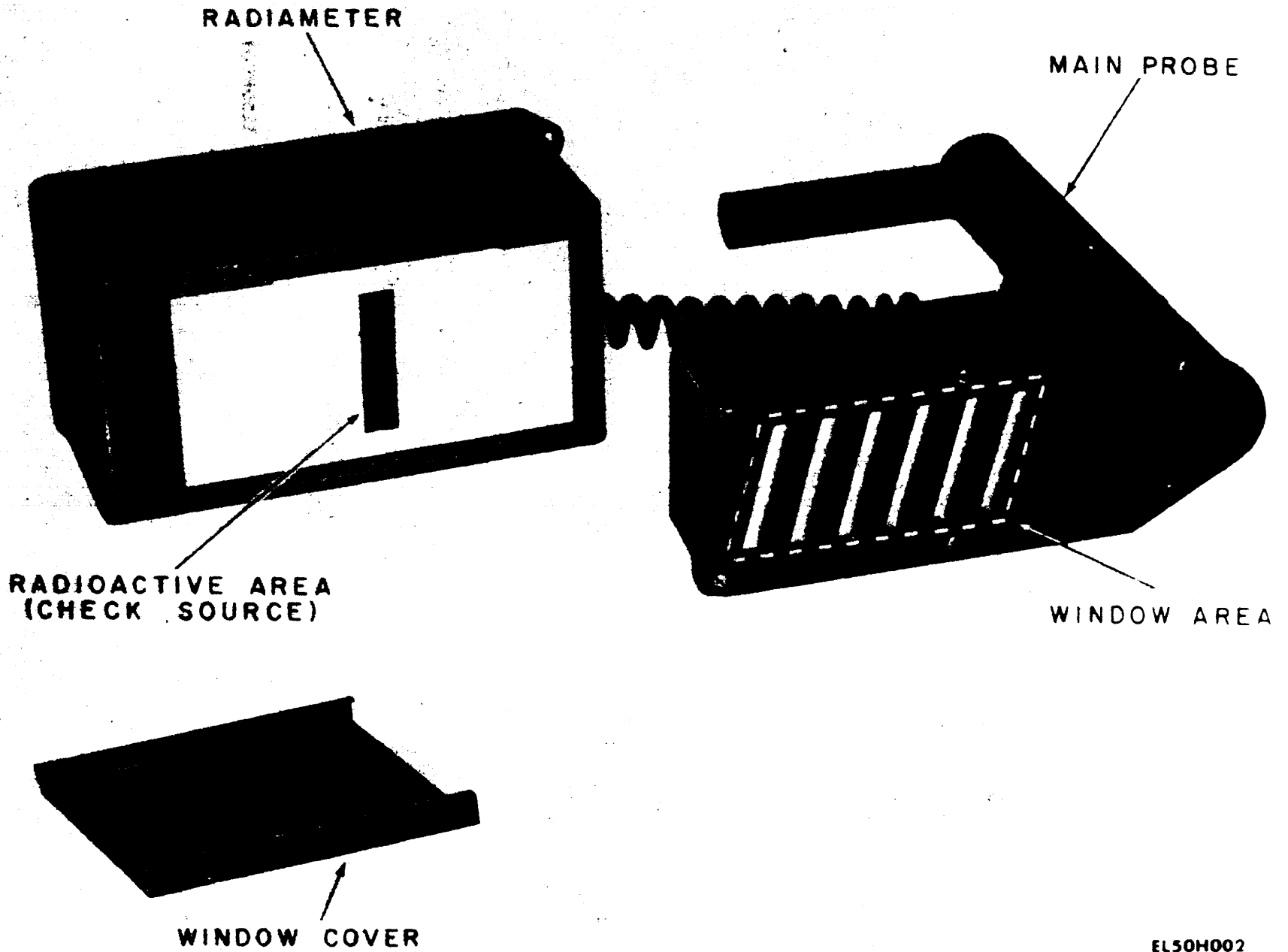

Figure 1-1. Radiac Set, AN/PDR-56F Components



EL50H002

Figure 1-2. Radiacmeter IM-160F/PDR-56

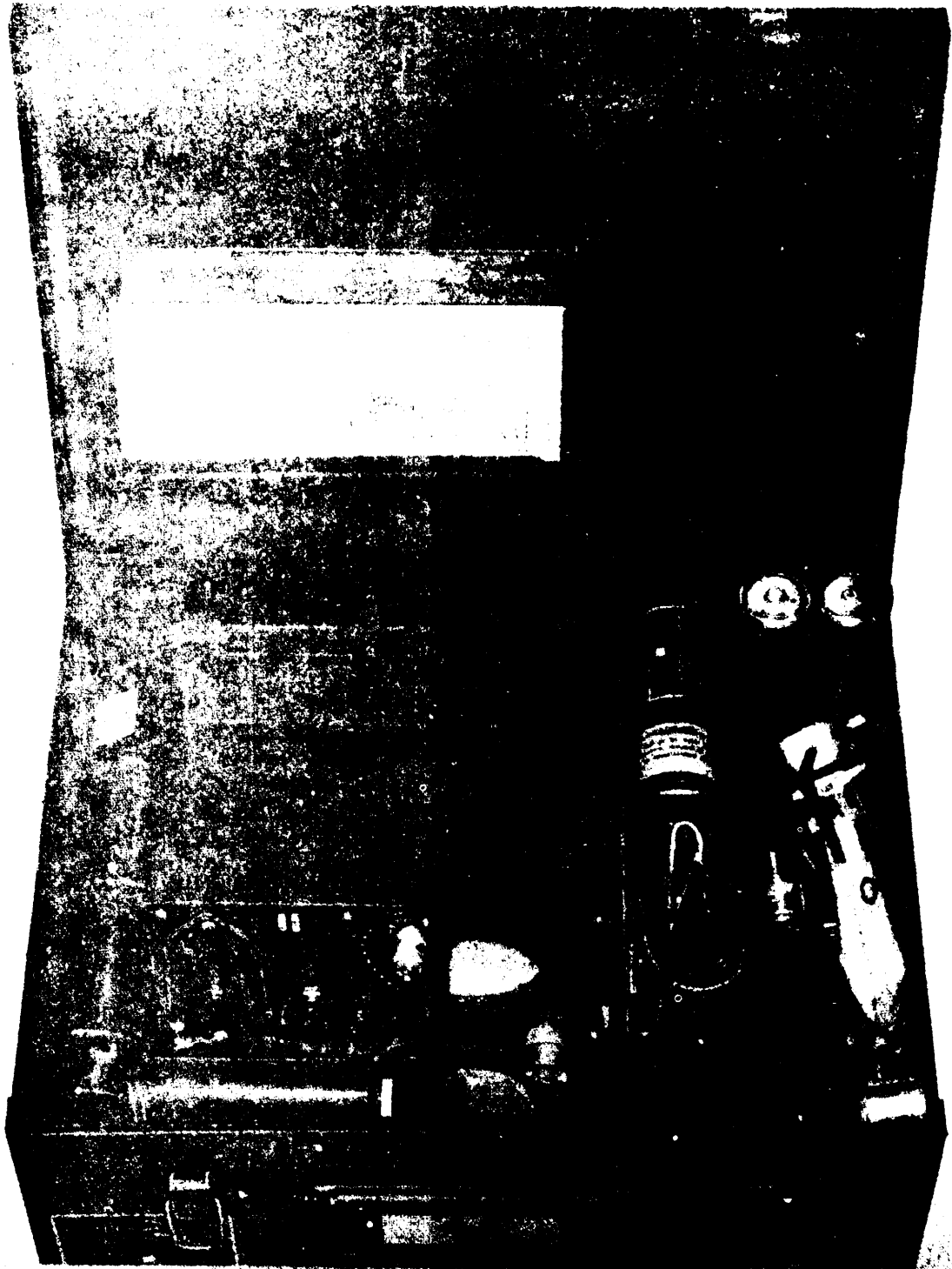

Figure 1-3. Case, Radiac Set CY-7375/PDR-56F

## CHAPTER 2 OPERATING INSTRUCTIONS

### 2-1. Operator Controls (Figure 2-1)

Refer to Table 2-1 for operator controls and indicators.

Table 2-1. Operator's Controls and Indicators

CONTROL, INDICATOR, OR CONNECTOR	FUNCTION														
Indicating Meter	Indicates battery condition or counts per minutes in four ranges depending on selector switch position.														
Selector Switch (6 position rotary switch)	<p>Turns radiacmeter on and off. Changes internal circuits and indicating meter to check batteries and measure alpha radiation as follows:</p> <table style="width: 100%; border-collapse: collapse;"> <thead> <tr> <th style="text-align: left;">Sw. Pos.</th> <th style="text-align: left;">Meter Indication</th> </tr> </thead> <tbody> <tr> <td>OFF</td> <td>Radiacmeter is off (all other positions: equipment is on).</td> </tr> <tr> <td>BATT</td> <td>Batteries are good if needles in BATT area of meter scale.</td> </tr> <tr> <td>1M</td> <td>Alpha radiation is measured from .0 to 1 million counts per minute (CPM).</td> </tr> <tr> <td>100K</td> <td>Same as position 1M except that measurement range is 0 to 100,000 counts per minute (CPM).</td> </tr> <tr> <td>10K</td> <td>Same as position 1M except that measurement range is 0 to 10,000 counts per minute (CPM).</td> </tr> <tr> <td>1K</td> <td>Same as position 1M except that measurement range is 0 to 1,000 counts per minute (CPM).</td> </tr> </tbody> </table>	Sw. Pos.	Meter Indication	OFF	Radiacmeter is off (all other positions: equipment is on).	BATT	Batteries are good if needles in BATT area of meter scale.	1M	Alpha radiation is measured from .0 to 1 million counts per minute (CPM).	100K	Same as position 1M except that measurement range is 0 to 100,000 counts per minute (CPM).	10K	Same as position 1M except that measurement range is 0 to 10,000 counts per minute (CPM).	1K	Same as position 1M except that measurement range is 0 to 1,000 counts per minute (CPM).
Sw. Pos.	Meter Indication														
OFF	Radiacmeter is off (all other positions: equipment is on).														
BATT	Batteries are good if needles in BATT area of meter scale.														
1M	Alpha radiation is measured from .0 to 1 million counts per minute (CPM).														
100K	Same as position 1M except that measurement range is 0 to 100,000 counts per minute (CPM).														
10K	Same as position 1M except that measurement range is 0 to 10,000 counts per minute (CPM).														
1K	Same as position 1M except that measurement range is 0 to 1,000 counts per minute (CPM).														
Meter Reset (momentary push button switch)	Reset indicating meter rapidly to zero.														
Light Switch (momentary push button switch)	Applies battery power to small lamp inside indicating meter to illuminate indicating meter face.														
Headphone Connector	Used to connect CPM electrical signal to earphones.														

## 2-2. Initial Procedures

Perform the procedures below to place the radiacmeter into operation:

### **CAUTION**

Protect the main probe, aux probe and x-ray probe window areas from sharp objects which could damage the light barrier. The light barrier is very thin and easily punctured which will cause the equipment to become inoperative. Keep the main and auxiliary probe window covers (Figure 1-2) in place when the radiacmeter is not in use.

#### *a. Operator Check for Main Probe.*

(1) Open the storage case and remove the radiacmeter and main probe from their storage position. Set the radiacmeter with main probe attached, upright on a flat surface.

(2) Loosen the two battery compartment cover screws (Figure 2-1) and remove the battery compartment cover.

(3) Install two BA-30 batteries into the radiacmeter. Follow the plus and minus marking on the case for the proper battery position. Reinstall the battery compartment cover.

(4) Set the selector switch to the BATT position and check the batteries.

(5) Loosen the probe handle retaining nut (Figure 2-1) and separate the main probe from the radiacmeter. Remove the main probe window cover.

(6) Set the selector switch to the 10K position and place the main probe window area over the check source (Figure 2-2) on the bottom of the radiacmeter. Fit the main probe and radiacmeter at a right angle to get as close as possible to the check source.

### **WARNING**

The check source used in this equipment contains Thorium (a radioactive metal). Thorium is a hazardous material. Injury or disease may result if the check source is not handled properly. Use extreme care not to touch, scratch, break, or remove the surface of the check source while handling them. See the front of this technical manual for first aid procedures.

(7) Read the indicating meter when the check source and the main probe are in contact.

The reading should be 6000 + 1200 CPM if the equipment is operating properly.

#### *b. Operator Check for X-Ray Probe.*

(1) Follow procedures in paragraph 2-2.a, then set selector switch to OFF.

(2) Disconnect the coil cord cable from the main probe and connect to the x-ray probe (Figure 2-3).

(3) Detach the probe handle from the main probe and attach to the x-ray probe (Figure 2-3).

(4) Set the selector switch to the 10K position and center the x-ray probe window as close as possible over the check source on the bottom of the radiacmeter (Figure 2-4).

(5) Read the indicating meter when the check source and the main probe are in contact. The reading should be between 4,000 and 10,000 counts per minute.

## 2-3. Monitoring Terrain, Supplies, and Equipment.

*a. General.* The main (or aux probe) and the x-ray probe are used to monitor terrain, supplies, or equipment. Remember that the window areas of each type probe are fragile and can be punctured or damaged easily.

*b. Procedures for Using the Main Probe (or Aux Probe).* Adjust the radiacmeter and use the procedure below for monitoring large open areas. In areas where space is limited, use the aux probe (Paragraph 2-4).

(1) Place the radiacmeter into operation by performing the procedures in Paragraph 2-2, above.

(2) Determine the best configuration for use and connect equipment as outlined below:

*(a) Main Probe Attached.* Radiacmeter can be used with the main probe attached to the radiacmeter (Figure 1-1).

*(b) Main Probe Detached.* Remove the main probe from the radiacmeter by loosening the main probe handle retaining nut and separating the two units. Attach the carrying strap to the radiacmeter case and place the carrying strap around your neck or on your shoulder to aid in carrying.

*(c) Main Probe Extended.* Connect the handle extension (Figure 1-1) to the main probe by removing the handle from the main probe body and inserting the handle extension between the two.

(3) Set the selector switch to the 1K position and proceed with monitoring while watching the indicating meter.

**NOTE**

In certain situations, it is inconvenient to constantly watch the indicator meter for radiation. In those cases, the operator should wear the headset. Connect the headset to the headset connector on the radiacmeter and listen for the sound of clicks generated by radiation detected by the main probe (or aux probe). When listening in an area of no radiation, random clicks (below 100 CPM) are heard. As an area of radiation is detected by the probe, the clicks come much faster and are accompanied by higher meter readings.

(4) When an area of radiation is detected by the main probe (or aux probe), the CPM reading on the indicating meter will increase. Shift the selector switch to the 10K, 100K, and 1M positions as the indicating meter needle moves off the scale.

**NOTE**

When changing to higher measurement positions, the indicating meter needle might remain to the right (off the scale). In this case, press the METER RESET switch.

c. *Procedures for Using the X-Ray Probe.* Perform Operator Check of X-Ray Probe (Para. 2-2.b) and use the following procedure for monitoring areas suspected of low energy gamma radiation contamination.

**NOTE**

There is no waiting time after connecting the x-ray probe.

- (1) Slowly scan with the probe window 6 to 12 inches from the suspected object or area.
- (2) The extension handle may be attached to the x-ray probe by removing the probe and inserting the extension between the handle and the probe.
- (3) Operate on the most sensitive range that does not result in an off-scale meter reading.

**2-4. Monitoring Personnel**

The aux probe is used to monitor personnel or to be used in confined spaces for monitoring where the main probe cannot be used. The aux probe is installed in place of the main probe on the main probe handle prior to use.

a. Remove the main probe from the radiacmeter by loosening the handle retaining nut and sliding the two apart.

**NOTE**

In the following procedure, the photomultiplier tube in the main probe handle will be uncovered. It must not be exposed to any light at all when the equipment is OFF, or exposed to any light at all when the equipment is ON. Such exposure will damage the photomultiplier tube and shorten its life. Take the following precautions:

Change the main probe with aux probe in a darkened room. Set the selector switch to OFF or remove batteries.

b. Remove two binder head 1/4 inch screws (Figure 2-5) from the main probe handle (below the cable connector). Retain the screws.

c. Grip the handle and the main probe body on each side of where they separate (right above where the screws were removed). Slowly pull the two apart using a twisting motion.

d. Remove the plastic plug from the aux probe and insert it into the large probe opening.

e. Slip the aux probe over the photomultiplier tube exposed in c above and rotate while slowly pressing it onto the handle. Line up the holes in the aux probe with the screw holes in the handle. Replace the two binder head screws in the handle.

**WARNING**

The check source used in this equipment contains Thorium (a radioactive metal). Thorium is a hazardous material. Injury or disease may result if the check source is not handled properly. Use extreme care not to touch, scratch, break, or remove the surface of the check source while handling them. See the front of this technical manual for first aid procedures.

f. Test the aux probe for light tightness as follows:

- (1) Perform initial procedures of installing batteries, checking batteries, and placing the aux probe against the check source as in paragraph 2-2 to determine proper operation.

**NOTE**

The aux probe is not calibrated; therefore, there is no standard CPM value when using the check source.

(2) After determining proper operation of radiacmeter, expose the aux probe window area to a light source while watching the indicating meter. Any light leaks will cause the meter to show some CPM value. This value is an error, which must be eliminated before the radiacmeter can be used.

g. Monitor personnel using a systematic procedure. Move the aux probe to cover all body

areas exposed to radiation. Move the probe slowly and hold it close to the body but without touching it. In most cases, it will be necessary to listen on the headset rather than watching the indicating meter, unless two persons are doing the monitoring.

**2-5. Equipment Shutdown**

After mission or equipment use, shut down equipment as follows:

- a. Remove the batteries from the radiacmeter and store them in the storage case.
- b. Place all accessory items into their proper positions in the storage case (Figure 1-3) and close the cover.

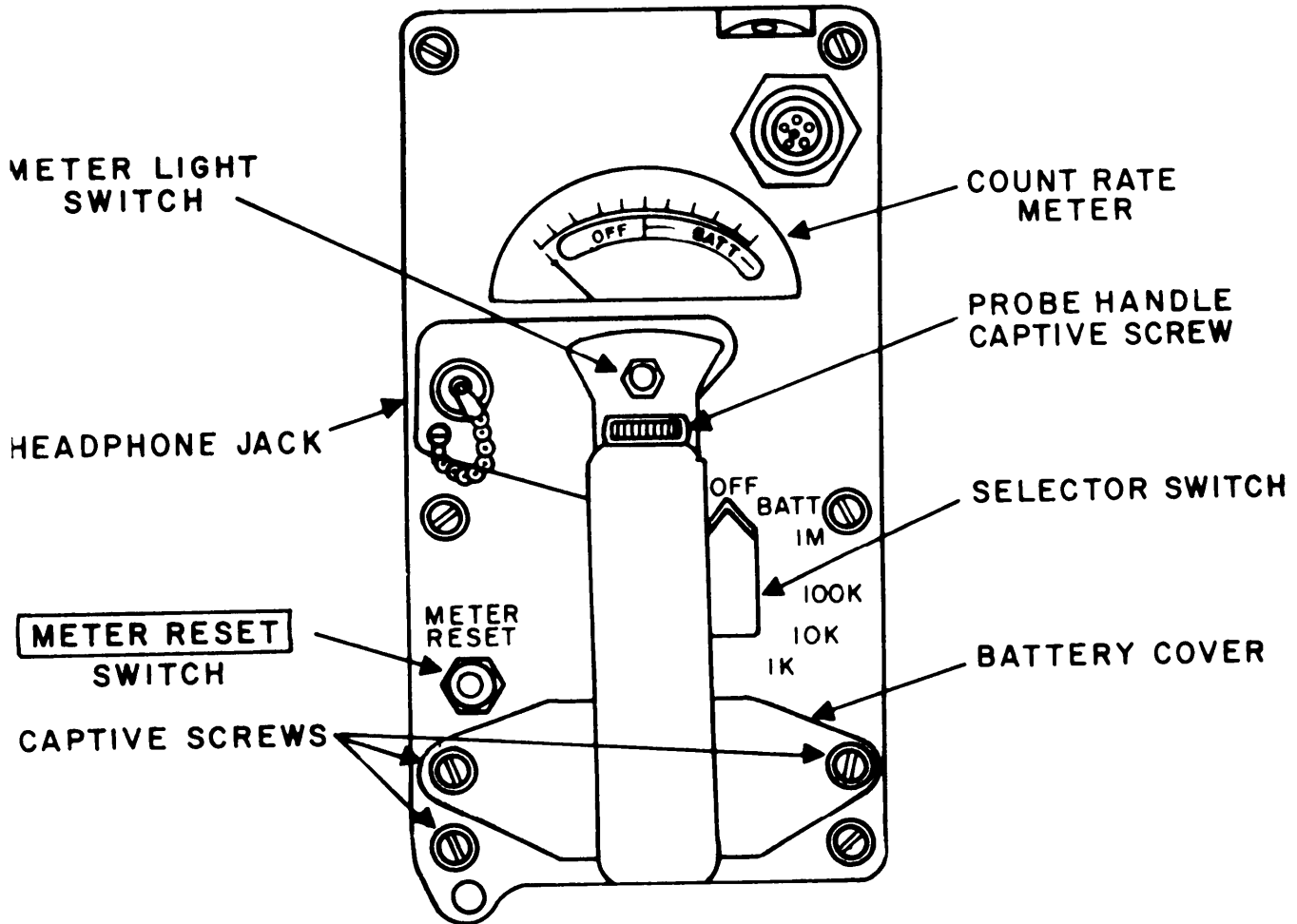

EL50H004

Figure 2-1. Operator's Controls and Indicators



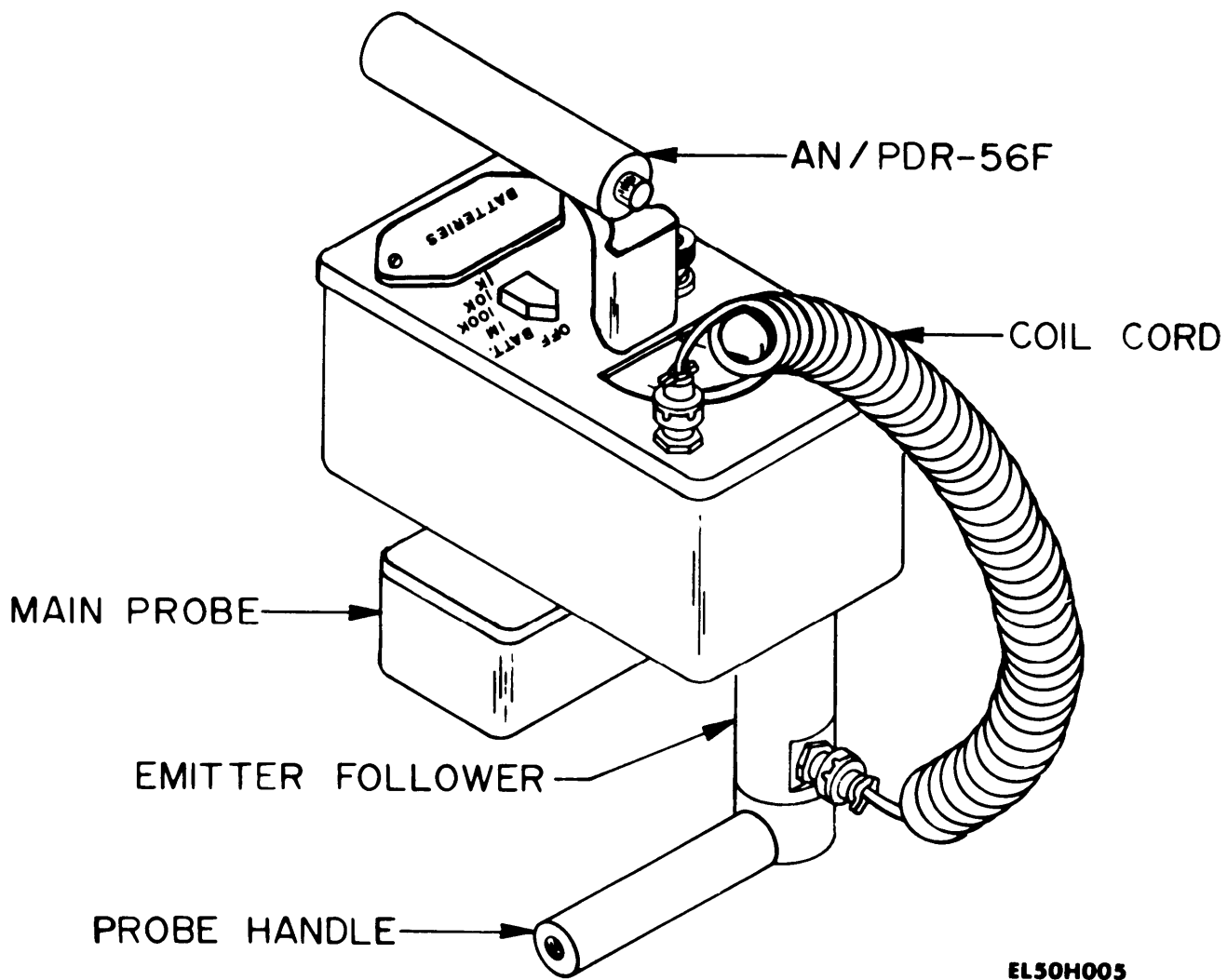

Figure 2-2. Radiac Probe DT-224B/PDR-56 Positioned Over Check Source

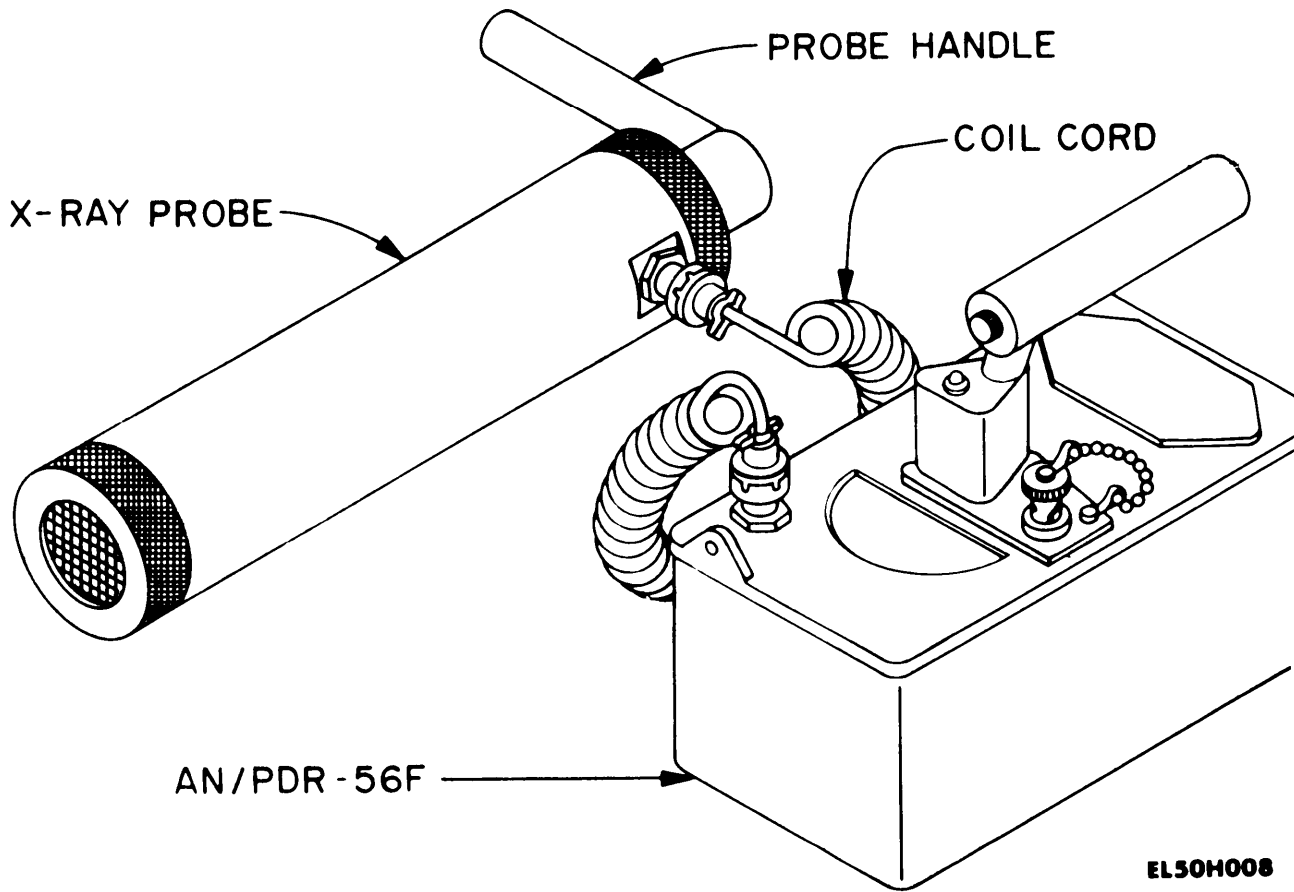
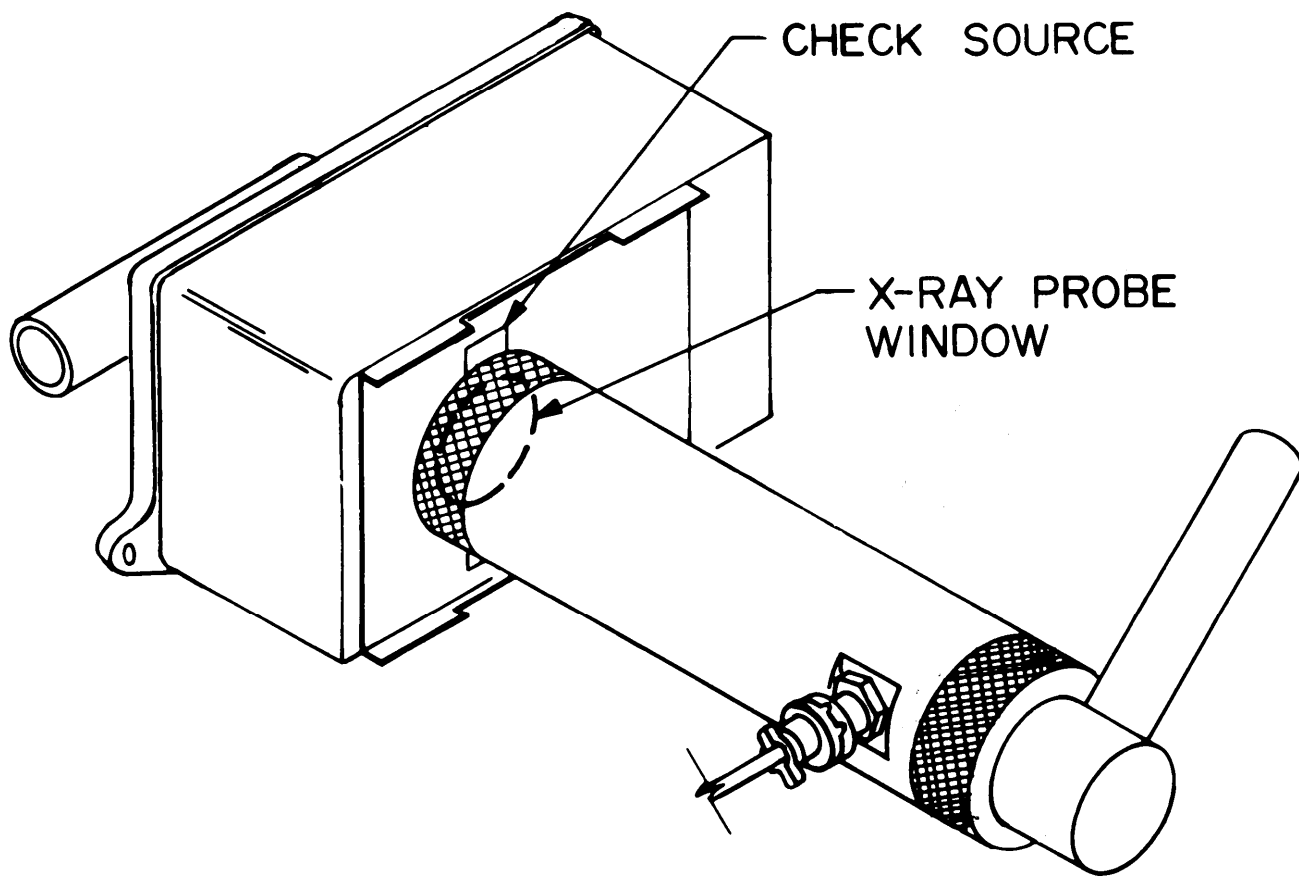
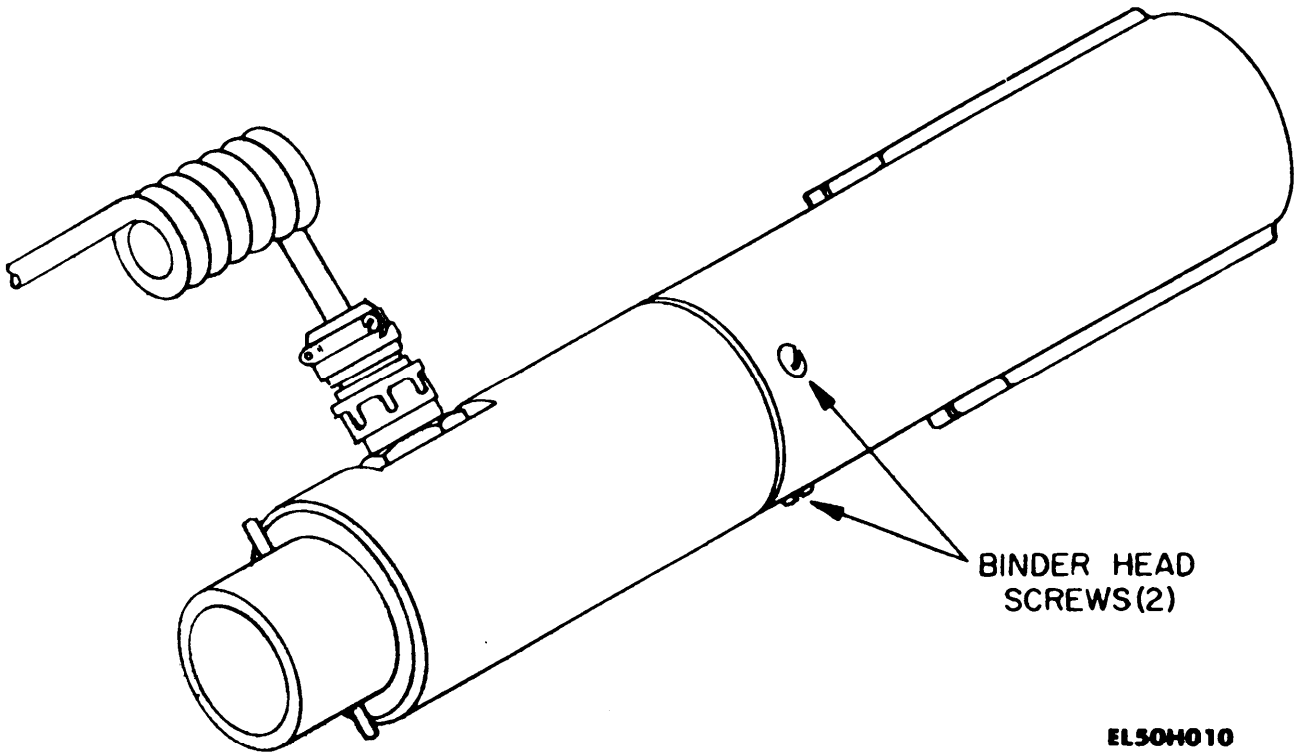

Figure 2-3. AN/PDR-56F with X-Ray Probe, DT-590A/PDR-56



EL50H009

■ Figure 2-4. X-Ray Probe DT-590A/PDR-56 Positioned Over Check Source



*Figure 2-5. Aux Probe Installed on Main Probe Handle*

## CHAPTER 3 OPERATOR MAINTENANCE INSTRUCTIONS

---

### 3-1. Scope of Maintenance

a. The maintenance duties of the operator are to perform a prescribed sequence of preventive maintenance procedures. The preventive maintenance procedures provide for the systematic care, servicing, and inspection of the equipment to prevent the occurrence of trouble and to reduce downtime.

b. These checks and services are also to maintain the equipment in a mission ready condition. The checks and services for AN/PDR-56F are as follows:

- (1) Routine services (Para. 3-3)
- (2) Cleaning (Para. 3-5)

### 3-2. Tools, Materials, and Equipment Required for Maintenance

a. No equipment is required for operator maintenance. Tool Kit, Electronic Equipment TK 101/G is required by the operator.

b. The following cleaning materials will be useful to the operator:

- (1) Soap and water
- (2) Lint-free cloths
- (3) Glass cleaner
- (4) Small soft bristle brush

### 3-3. Routine Services

Routine services are checks and observations performed by the operator at all times. Routine services are not scheduled preventive maintenance checks and services.

a. *Routines.* The operator should perform the following routines as necessary:

- (1) Cleaning (Para. 3-5)
- (2) Check for cut or frayed cables.
- (3) Check for dented, bent, or broken components.
- (4) Check to see that items not in use are properly stowed.
- (5) Check for rusting.
- (6) Check controls for smooth operation.
- (7) Cover unused receptacles, where applicable.
- (8) Check for loose hardware and connectors.
- (9) Check to see that nameplates are clean and legible.
- (10) Check for completeness of equipment.

b. *Items Requiring Routine Services.*

- (1) Storage Case
- (2) Radiacmeter, including battery compartment.
- (3) Main Probe
- (4) Aux Probe
- (5) X-Ray Probe
- (6) Headset
- (7) Extension Handle
- (8) Harness

### 3-4. Operator Preventive Maintenance Checks and Services (PMCS)

There is no PMCS to be performed on Radiac Set AN/PDR-56F.

### 3-5. Cleaning

Inspect all exposed surfaces of the equipment. These surfaces should be free of dust, dirt, grease, and fungus.

a. Use the lint-free cloth to remove dust and loose dirt.

#### CAUTION

Do not press on the radiacmeter indicating meter glass when cleaning; the meter may be damaged.

b. Using a cloth dampened (not wet) with soap and water, remove grease, fungus, and hard to remove dirt.

c. Use the soft bristle brush to remove dust and dirt from areas hard to reach with the cleaning cloth.

### 3-6. Troubleshooting

Operator troubleshooting procedure shall be as follows:

a. With the radiacmeter in an operating mode, if the indicating meter on the front panel does not indicate, or exhibits a low reading, the operator should replace the batteries with new ones.

b. With the radiacmeter in an operating mode, if the needle on the indicating meter swings below zero (to the left of zero), the operator should check to see if the batteries have been installed backwards. If they have, the operator should reverse the battery positions and check the radiacmeter for proper operation.

c. If battery replacement or reversal cannot correct the problem, the equipment requires a higher category of maintenance.

# CHAPTER 4 ORGANIZTIONAL MAINTENANCE INSTRUCTIONS

## Section I. TOOLS AND EQUIPMENT

### 4-1. Tools and Equipment Required

Tools and equipment authorized at the organizational category of maintenance are as follows:

- a. Tool Kit, Electronic Equipment TK-101/G.
- b. Multimeter AN/USM-223.

### 4-2. Materials Required for Maintenance

For a list of materials required for organizational maintenance of the radiac set refer to appendix C.

## Section II. Repainting AND Refinishing INSTRUCTIONS

### 4-3. Preparation for Painting

Remove rust and corrosion from metal surfaces by lightly sanding with fine sandpaper.

### 4-4. Priming

Apply one coat of zinc chromate primer to the sanded

area.

### 4-5. Touchup Painting

Brush two coats of paint on the primed metal to prevent it from further corrosion. Refer to the applicable cleaning and refinishing particles specified in SB 11-573 and TB 43-0118.

## Section III. TROUBLESHOOTING

### 4-6. General Troubleshooting Instructions

Troubleshooting of the radiac set is based on the system operational check contained in the operator troubleshooting procedure discussed in section 3-6. To troubleshoot the Radiac Set, note any unusual performance or condition during the operational check. Look for the corresponding symptom in the troubleshooting chart (table 4-1) and perform the corrective measures indicated. If the corrective measures do not remedy the trouble, or if the corresponding symptom is not listed, higher category of maintenance is required.

### 4-7. Troubleshooting by Visual Inspection

The following visual inspections should be made before performing the troubleshooting procedures in table 4-1:

a. Radiacmeter.

(1) Make sure that the main probe coil cord is fully connected to the front panel connector and tight.

(2) Make sure that headset bayonet connector is fully plugged into the front panel connector and securely locked in place.

(3) Make sure that the batteries are properly installed.

(4) Make sure that the front panel selector switch is in the desired ON position.

Table 4-1. Troubleshooting Chart

Symptom	Probable Trouble	Corrective Measures
Meter reads zero with range switch at BATT.	<ul style="list-style-type: none"> <li>a. Batteries dead or missing.</li> <li>b. Poor battery connection.</li> <li>c. Switch knob loose.</li> </ul>	<ul style="list-style-type: none"> <li>a. Replace batteries.</li> <li>b. Clean connections.</li> <li>c. Tighten switch knob set screw.</li> </ul>
Meter pointer swings below zero.	Batteries installed in reverse position.	Reverse battery position.
No indication when tested with a check source.	<ul style="list-style-type: none"> <li>a. Faulty probe.</li> <li>b. Faulty coil cord.</li> </ul>	<ul style="list-style-type: none"> <li>a. Replace probe.</li> <li>b. Replace coil cord.</li> </ul>
Front panel meter indicates but no audible sound in headset.	Faulty headset.	Replace headset.

## Section IV. MAINTENANCE OF THE RADIAC SET

### 4-8. Maintenance of the Radiacmeter

*a. Headset BNC Type Connector Cap Replacement.* This connector is located just below the indicating meter on the left-hand side of the radiacmeter front panel (fig. 4-1). If the connector cap is damaged or missing, replace as follows:

(1) Using a screwdriver, remove the screw that retains the cap chain to the front panel. Do not discard the screw.

(2) Twist the cap, mounted on the BNC connector, counterclockwise to unlock it from the connector, and lift it off the connector.

(3) Plug a new cap firmly into the connector, and twist it clockwise to lock it in place.

(4) Place the screw through the eyelet on the free end of the cap chain, and reinstall the screw into the radiacmeter front panel.

*b. Selector Switch Knob.* Located at the center right of the radiacmeter front panel (fig 4-1). If this knob becomes loose, damaged or is missing, replace or retighten as follows:

(1) Determine what scale the radiacmeter is set to by observing the indicating meter scale.

(2) If the knob is missing, place a new knob on the selector switch shaft. If the knob is damaged, use a small blade screwdriver to loosen the screw in the knob and remove the damaged knob. Replace with a new knob.

(3) Line up the knob with the front panel marking that agrees with the indicating meter scale (OFF, BATT, 1M, 100K, or 1K).

(4) Using the small blade screwdriver, tighten the knob screws so that the knob position is in agreement with the meter scale.

### 4-9. Preparation for Storage or Shipment

*a. Preparation for Storage.* The following items must be completed or considered prior to storing the equipment.

(1) Security of the stored items is required. The

stored area must prevent items from being stolen.

(2) Items stored must be protected from the weather. Covered storage is required.

(3) Items to be stored must be in good working order. Equipment that is inoperative cannot be stored. Perform an operation check (para 2-2) of the equipment prior to storage. Remove all batteries from the equipment and storage case prior to storage.

(4) In the case of items put into administrative storage (1-45 days), the storage area must be accessible. The equipment in storage must be able to be put into operation within 24 hours.

*b. Preparation for Shipment.* The radiac set is shipped in its storage case without any internal packing or cushioning material. The storage case itself must be protected during shipment by packing it in an oversized corrugated fiber board box. The space inside the packing box, at least 1 to 2 inches all around the storage case, must be filled with cushioning and blocking material to prevent movement. The packing box should then be surrounded with some form of vapor barrier and sealed. Next, the packing box with vapor barrier in place should be placed inside another corrugated fiber board box and sealed.

*c. Battery Compartment Gasket Replacement.* Should the battery compartment cover gasket (fig. 4-1) become detached or damaged, replace as follows:

(1) Remove any portion of the old gasket from the battery compartment cover by peeling or lightly scraping.

(2) Clean the cover of all residue using soap and water and a cleaning cloth. This surface must be thoroughly clean and dry.

(3) Apply a light coating of adhesive (item 6, appx D) to both the gasket and the battery compartment cover.

(4) Place the gasket firmly onto the battery compartment cover, in the correct position.

(5) Wait at least 30 minutes before reinstalling cover.

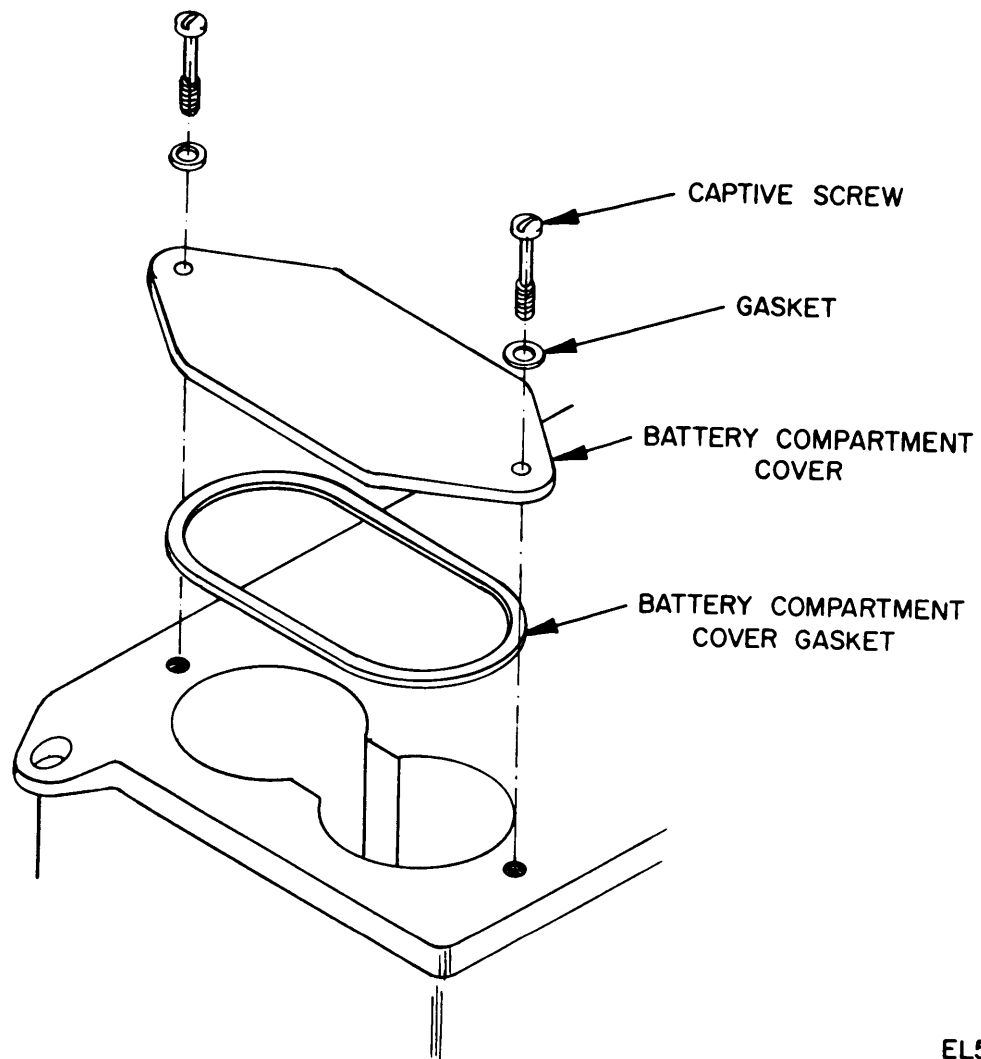

EL50H006

Figure 4-1. Battery compartment cover, exploded view.



## APPENDIX A REFERENCES

---

AR 70-58	Packaging Improvement Report.
DA Pam 738-750	The Army Maintenance Management System (TAMMS)
SB 11-573	Painting and Preservation of Supplies Available for Field Use for Electronics Command Equipment.
TB 43-0118	Field Instructions for Painting and Preserving Electronics Command Equipment Including Camouflage Pattern Painting of Electrical Equipment Shelter.
DA Pam 310-1	Consolidated Index of Army Publications and Blank Forms.
TM 750-244-2	Procedures for Destruction of Electronics Materiel to Prevent Enemy Use (Electronics Command).

## APPENDIX B

### COMPONENTS OF END ITEM LIST

---

#### B-1. Scope

This appendix lists integral components of and basic issue items for the AN/PRD-56F to help you inventory items required for safe and efficient operation.

#### B-2. General

This Components of End Item List is divided into the following sections:

a. *Section II. Integral Components of the End Item.* These items, when assembled, comprise the AN/PDR-56F and must accompany it whenever it is transferred or turned in. The illustration (Figure B-1) will help you identify these items.

b. *Section III. Basic Issue Items.* Not applicable.

#### B-3. Explanation of Columns

a. *Illustration.* This column is divided as follows:

(1) *Figure number.* Indicates the figure number of the illustration on which the item is shown.

(2) *Item number.* The number used to identify item called out in the illustration.

b. *National Stock Number.* Indicates the national stock number assigned to the item and which will be used for requisitioning.

c. *Part Number.* Indicates the primary number used by the manufacturer, which controls the design and characteristics of the item by means of its engineering drawings, specifications, standards, and inspection requirements to identify an item or range of items. Following the part number,

the Federal Supply Code for Manufacturers (FSCM) is shown in parentheses.

d. *Description.* Indicates the Federal item name and, if required, a minimum description to identify the item.

e. *Location.* The physical location of each item listed is given in this column. The lists are designed to inventory all items in one area of the major item before moving on to an adjacent area.

f. *Usable on Code.* Not applicable.

Code

Used On

g. *Quantity Required (Qty Reqd).* This column lists the quantity of each item required for a complete major item.

h. *Quantity.* This column is left blank for use during an inventory. Under the Rcvd column, list the quantity you actually receive on your major item. The Date columns are for your use when you inventory the major item at a later date; such as for shipment to another site.

#### B-4. Special Information

National Stock Numbers (NSNs) that are missing from Section II have been applied for and will be added to this TM by future change/revision when they are entered in the Army Master Data File (AMDF). Until the NSNs are established and published, submit exception requisitions to: Commander, US Army Communications and Electronics Materiel Readiness Command, ATTN: AM-SEL-MM, Fort Monmouth, NJ 07703-5006 for the part required to support your equipment.

X-RAY PROBE  
(BELOW ITEMS-2 & 4)

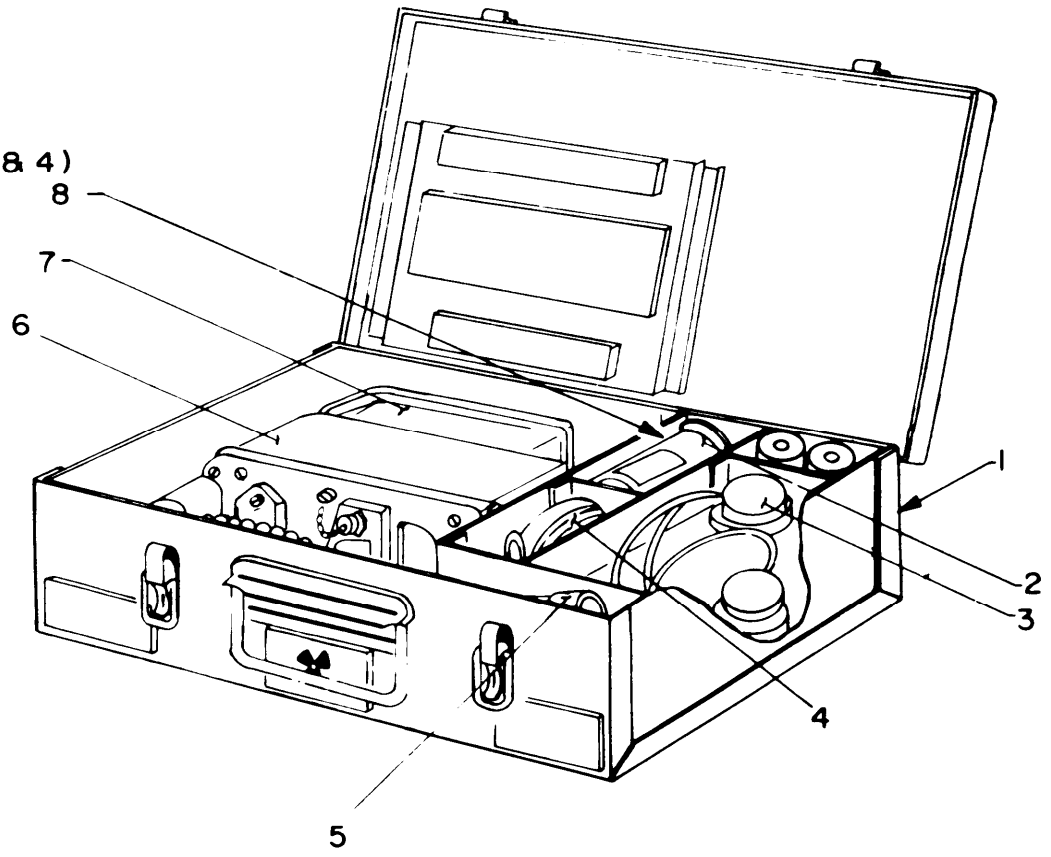

**EL50H011**

Figure B-1. Components of Radiac Set

**Section II. INTEGRAL COMPONENTS OF END ITEM  
RADIAC SET AN/PDR-56F**

(1) Illustration		(2) National Stock Number	(3) Description		(4) Location	(5) Usable On Code	(6) Qty Reqd.	(7) Quantity	
(A) Fig. No.	(B) Item No.		Part Number	(FSCM)				Rcvd	Date
	2		Auxiliary Probe (96696) Assy B4177			1			
	3		Headphone, H-43 (96696) B/U C3898			1			
	4		Carrying Strap (96696) Assy B1031			1			
	5		Probe Handle (96696) Extension B1112			1			
	6		Radiacmeter (96696) Assy D3853			1			
	7		Main Probe (96696) Assy D4179			1			
	8		X-Ray Probe (96696) Assy 07283			1			

DRSEL-MA Form 6010, (1 MAR 77)

(Edition of 1 JUN 76 is obsolete)

HISA-FM 545-77

# APPENDIX C

## MAINTENANCE ALLOCATION

---

### Section I. INTRODUCTION

#### C-1. General.

This appendix provides a summary of the maintenance operations for AN/PDR-56F. It authorizes categories of maintenance for specific maintenance functions on repairable items and components and the tools and equipment required to perform each function. This appendix may be used as an aid in planning maintenance operations.

#### C-2. Maintenance Function.

Maintenance functions will be limited to and defined as follows:

*a. Inspect.* To determine the serviceability of an item by comparing its physical, mechanical, and/or electrical characteristics with established standards through examination.

*b. Test.* To verify serviceability and to detect incipient failure by measuring the mechanical or electrical characteristics of an item and comparing those characteristics with prescribed standards.

*c. Service.* Operations required periodically to keep an item in proper operating condition, i.e., to clean (decontaminate), to preserve, to drain, to paint, or to replenish fuel, lubricants, hydraulic fluids, or compressed air supplies.

*d. Adjust.* To maintain, within prescribed limits, by bringing into proper or exact position, or by setting the operating characteristics to the specified parameters.

*e. Align.* To adjust specified variable elements of an item to bring about optimum or desired performance.

*f. Calibrate.* To determine and cause corrections to be made or to be adjusted on instruments or test measuring and diagnostic equipments used in precision measurement. Consists of comparisons of two instruments, one of which is a certified standard of known accuracy, to detect and adjust any discrepancy in the accuracy of the instrument being compared.

*g. Install.* The act of emplacing, seating, or fixing into position an item, part, module (component or assembly) in a manner to allow the proper functioning of the equipment or system.

*h. Replace.* The act of substituting a serviceable like type part, subassembly, or module (component or assembly) for an unserviceable counterpart.

*i. Repair.* The application of maintenance services (inspect, test, service, adjust, align, calibrate, replace) or other maintenance actions (welding, grinding, riveting, straightening, facing, remachining, or resurfacing) to restore serviceability to an item by correcting specific damage, fault, malfunction, or failure in a part, sub-

assembly, module (component or assembly), end item, or system.

*j. Overhaul.* That maintenance effort (service/action) necessary to restore an item to a completely serviceable/operational condition as prescribed by maintenance standards (i.e., DMWR) in appropriate technical publications. Overhaul is normally the highest degree of maintenance performed by the Army. Overhaul does not normally return an item to like new condition.

*k. Rebuild.* Consists of those services/actions necessary for the restoration of unserviceable equipment to a like new condition in accordance with original manufacturing standards. Rebuild is the highest degree of materiel maintenance applied to Army equipment. The rebuild operation includes the act of returning to zero those age measurements (hours, miles, etc.) considered in classifying Army equipments/components,

#### C-3. Column Entries.

*a. Column 1, Group Number.* Column 1 lists group numbers, the purpose of which is to identify components, assemblies, subassemblies, and modules with the next higher assembly.

*b. Column 2, Component/Assembly.* Column 2 contains the noun names of components, assemblies, subassemblies, and modules for which maintenance is authorized.

*c. Column 3, Maintenance Functions.* Column 3 lists the functions to be performed on the item listed in column 2. When items are listed without maintenance functions, it is solely for purpose of having the group numbers in the MAC and RPSTL coincide.

*d. Column 4, Maintenance Category.* Column 4 specifies, by the listing of a "work time" figure in the appropriate subcolumn(s), the lowest level of maintenance authorized to perform the function listed in column 3. This figure represents the active time required to perform that maintenance function at the indicated category of maintenance. If the number or complexity of the tasks within the listed maintenance function vary at different maintenance categories, appropriate "work time" figures will be shown for each category. The number of task-hours specified by the "work time" figure represents the average time required to restore an item (assembly, subassembly, component, module, end item or system) to a serviceable condition under typical field operating conditions. This time includes preparation time, troubleshooting time, and quality assurance/quality control time in addition to the time required to perform the specific tasks identified for

the maintenance functions authorized in the maintenance allocation chart. Subcolumns of column 4 are as follows:

- C-Operator/Crew
- O-Organizational
- F-Direct Support
- H-General Support
- D-Depot

*e. Column 5, Tools and Equipment.* Column 5 specifies by code, those common tool sets (not individual tools) and special tools, test, and support equipment required to perform the designated function.

*f. Column 6, Remarks.* Column 6 contains an alphabetic code which leads to the remark in section IV, Remarks, which is pertinent to the item opposite the particular code.

#### **C-4. Tool and Test Equipment Requirements (Sect. III).**

*a. Tool or Test Equipment Reference Code.* The numbers in this column coincide with the numbers used

in the tools and equipment column of the MAC. The numbers indicate the applicable tool or test equipment for the maintenance functions.

*b. Maintenance Category.* The codes in this column indicate the maintenance category allocated the tool or test equipment.

*c. Nomenclature.* This column lists the noun name and nomenclature of the tools and test equipment required to perform the maintenance functions.

*d. National/NATO Stock Number.* This column lists the National/NATO stock number of the specific tool or test equipment.

*e. Tool Number.* This column lists the manufacturer's part number of the tool followed by the Federal Supply Code for manufacturers (5-digit) in parentheses.

#### **C-5. Remarks (Sect. IV.)**

*a. Reference Code.* This code refers to the appropriate item in section II, column 6.

*b. Remarks.* This column provides the required explanatory information necessary to clarify items appearing in section II.

(Next printed page is 44)

**SECTION II. MAINTENANCE ALLOCATION CHART  
FOR  
RADIAC SET AN/PDR-56F**

(1) GROUP NUMBER	(2) COMPONENT/ASSEMBLY	(3) MAINTENANCE FUNCTION	(4) MAINTENANCE CATEGORY					(5) TOOLS AND EQPT	(6) REMARKS
			C	O	F	H	D		
00	Radiac Set AN/PDR-56F	Inspect		0.1				1	
		Test		0.2				1, 4	
		Service		0.2					
		Replace		0.1					
		Repair				0.3		2 thru 7	A
01	Radiacmeter	Repair					1.5	2 thru 9	A
		Overhaul					4.0	2 thru 9	A
0101	Cover Assembly	Inspect		0.3				1	
		Test				0.4		2, 4	
		Repair				0.5		2, 3, 6	B
		Replace				0.3		2	A
		010101	Meter Linkage Assembly	Inspect			0.1		2
010102	Meter Light Assembly	Repair				0.2		2	
		Replace				0.2		2	
		Inspect				0.1		2, 4	
010103	Printed Circuit Board Assembly	Repair				0.2		2, 4	I
		Test				0.3		2	
0102	Radiacmeter Case and Source	Inspect				0.3		3, 5, 6	
		Test				0.3		3, 5, 6	B
		Repair				0.5		3, 5, 6	B
		Replace				0.3		2	B
02	Main Probe Assembly (Includes Emitter Follower)	Inspect		0.1				2	
		Repair				0.3		2	
		Replace				0.3		2	K, J, F
0201	Main Probe Base Assembly	Inspect				0.4		1	
		Test				1.0		2, 5, 7	
		Repair				0.1		2, 5, 6	A
		Replace				0.1		1	A
020101	Main Probe Window Assy.	Inspect				0.1		2	
		Test				0.3		3, 5, 7	
		Repair				0.5		2	D
		Replace				0.2		2	D
03	Auxiliary Probe Assembly	Inspect				0.2		2	
		Test				0.3		7	
		Repair				0.4		2	D
03	Auxiliary Probe Assembly	Replace				0.4		2	
		Inspect		0.2				1	
		Test				0.2		7	
03	Auxiliary Probe Assembly	Repair				0.4		2	
		Replace		0.1					E
03	Auxiliary Probe Assembly	Inspect							G
		Test							

**SECTION II. MAINTENANCE ALLOCATION CHART  
FOR  
RADIAC SET AN/PDR-56F**

(1) GROUP NUMBER	(2) COMPONENT/ASSEMBLY	(3) MAINTENANCE FUNCTION	(4) MAINTENANCE CATEGORY					(5) TOOLS AND EQPT	(6) REMARKS
			C	O	F	H	D		
0301	Auxiliary Probe Window Assembly	Inspect Test Repair Replace		0.1		0.3 0.4 0.2		1  2	C
04	X-Ray Probe Assembly	Inspect Test Replace Repair Repair Calibrate		0.1		0.2 0.1 0.2		1 2, 4, 5, 7 1, 7 2 2 thru 7, 10 2 thru 10	B L B, M
0401	PCB Assembly	Inspect Test Repair Replace				0.3 0.3		2 3, 5, 6 3, 5, 7, 10 2, 7, 10	B, M B, M
05	Case Radiac Set	Inspect Replace Repair		0.1 0.1			1.5	2	



**Section III. TOOL AND TEST EQUIPMENT REQUIREMENTS  
FOR  
RADIAC SET AN/PDR-56F**

Tool or Test Equipment Ref Code	Maintenance Category	Nomenclature	National/NATO Stock Number	Tool Number
1	O	Tool Kit, Electronic Equipment TK-101/G	5180-00-064-5178	
2	H, D	Tool Kit, Electronic Equipment TK-105/G	5180-00-610-8177	
3	H, D	Oscilloscope AN/USM-488	FSCM 80009 P/N 2235	
4	O, H, D	Multimeter AN/PSM-45	6625-01-139-2512	
5	H, D	Voltmeter, Digital AN/GSM-64A	6625-00-165-5779	
6	H, D	Multimeter AN/USM-486	6625-01-145-2430	
7	H, D	Calibrator, Radiac AN/UDM-7C	6665-01-084-7777	
8	D	Generator, Pulse AN/UPM-15 or AN/UPM-15A	6625-00-643-5969 6625-00-682-2581	
9	D	Counter, Electronic Digital Readout AN/USM-207	6625-00-911-6368	
10	D	Amersham Variable Energy X-Ray Source (Americium-241), Product Code AMC-2084		

**Section IV. REMARKS**

REFERENCE CODE	REMARKS
A	Radiacmeter, Main Probe Assembly, Emitter Follower Assembly and Photomultiplier Tube are calibrated as a unit; any replacement will require recalibration utilizing the AN/UDM-7 Radiac Calibrator.
B	Repair or Replacement of components requires recalibration.
C	Repair by replacement of scintillation screen and cover assembly (Requires Light Leak Test).
D	Replacement requires recalibration and Light Leak Test.
E	Repair or replacement requires checking using Emitter Follower.
F	Use Pliobond Adhesive.
G	Replace Window Guard Plastic only.
H	Repair includes replacement of BNC Cap, Selector Switch Knob and Battery Compartment Cover Gasket.
I	Repair by replacement of bulb.
J	Radioactive Source must be disposed of as radioactive waste (AR 385-11).
K	Repair by replacement of source or source frame.
L	Replace cap ring assembly and end cap assembly only.
M	Repair or replacement requires calibration check of x-ray probe with variable x-ray source.

# APPENDIX D

## EXPENDABLE SUPPLIES AND MATERIALS LIST

---

### Section I. INTRODUCTION

#### D-1. Scope

This appendix lists expendable supplies and materials you will need to operate and maintain the AN/PDR-56F. These items are authorized to you by CTA 50-970, Expendable Items (Except Medical, Class V, Repair Parts, and Heraldic Items).

#### D-2. Explanation of Columns

*a. Column 1 — Item number.* This number is assigned to the entry in the listing and is referenced in the narrative instructions to identify the material (e.g., "Use cleaning compound, item 5, App. D").

*b. Column 2 — Level.* This column identifies the lowest level of maintenance that requires the listed item.

C-Operator/Crew

O-Organizational Maintenance/Aviation Unit Maintenance

F—Direct Support Maintenance/Aviation Intermediate Maintenance

H—General Support Maintenance

*c. Column 3—National Stock Number.* This is the National stock number assigned to the item; use it to request or requisition the item.

*d. Column 4—Description.* Indicates the Federal item name and, if required, a description to identify the item. The last line for each item indicates the Federal Supply Code for Manufacturer (FSCM) in parentheses followed by a part number.

*e. Column 5—Unit of Measure (U/M).* Indicates the measure used in performing the actual maintenance function. This measure is expressed by a two-character alphabetical abbreviation (e.g., ea. in, pr). If the unit of measure differs from the unit of issue, requisition the lowest unit of issue that will satisfy your requirements.

(Next printed page is D-3)

SECTION II EXPENDABLE SUPPLIES AND MATERIALS LIST

(1) ITEM NO.	(2) LEVEL	(3) NATIONAL STOCK NUMBER	(4) DESCRIPTION  PART NO. AND FSCM	(5) UNIT OF MEAS
1	C	8305-00-222-2423	CLOTH, CLEANING F24M16 (48035)	YD
2	C	6135-00-120-1020	BATTERY BA-30/U	EA
3	O	5350-00-264-3485	PAPER, ABRASIVE	SH
4	O	5350-00-145-0147	PRIMER, ZINCCHROMATE	QT
5	O	8010-00-111-7937	ENAMEL, O.D. (81349)	GAL
6	O	8040-00-390-7959	ADHESIVE EC847 (76381)	QT

By Order of the Secretary of the Army:

EDWARD C. MEYER  
*General, United States Army*  
*Chief of Staff*

Official:

J. C. PENNINGTON  
*Major General, United States Army*  
*The Adjutant General*

Distribution:

To be distributed in accordance with DA Form 12-50, Organizational maintenance requirements for AN/PDR-60.

☆ U.S. GOVERNMENT PRINTING OFFICE : 1989 - 242 - 451 (5695)

RECOMMENDED CHANGES TO EQUIPMENT TECHNICAL PUBLICATIONS



THEN... JOT DOWN THE DOPE ABOUT IT ON THIS FORM. CAREFULLY TEAR IT OUT. FOLD IT AND DROP IT IN THE MAIL!

SOMETHING WRONG WITH THIS PUBLICATION?

FROM (PRINT YOUR UNIT'S COMPLETE ADDRESS)  
 Commander  
 Stateside Army Depot  
 ATTN: AMSTA-US  
 Stateside, N.J. 07703

DATE SENT 10 July 1975

PUBLICATION NUMBER  
 TM 11-5840-340-12

PUBLICATION DATE  
 23 Jan 74

PUBLICATION TITLE  
 Radar Set AN/PRC-76

BE EXACT PIN-POINT WHERE IT IS

PAGE NO	PARA-GRAPH	FIGURE NO	TABLE NO
2-25	2-28		
3-10	3-3		3-1
5-6	5-8		
		F03	

IN THIS SPACE TELL WHAT IS WRONG AND WHAT SHOULD BE DONE ABOUT IT:

Recommend that the installation antenna alignment procedure be changed throughout to specify a 2° IFF antenna lag rather than 1°.

REASON: Experience has shown that with only a 1° lag, the antenna servo system is too sensitive to wind gusting in excess of 25 knots, and has a tendency to rapidly accelerate and decelerate as it hunts, causing strain to the drive train. Hunting is minimized by adjusting the lag to 2° without degradation of operation.

Item 5, Function column. Change "2 db" to "3db."

REASON: The adjustment procedure the the TRANS POWER FAULT indicator calls for a 3 db (500 watts) adjustment to light the TRANS POWER FAULT indicator.

Add new step f.1 to read, "Replace cover plate removed in step e.1, above."

REASON: To replace the cover plate.

Zone C 3. On J1-2, change "+24 VDC to "+5 VDC."

REASON: This is the output line of the 5 VDC power supply. +24 VDC is the input voltage.

PRINTED NAME, GRADE OR TITLE AND TELEPHONE NUMBER  
 SSG I. M. DeSpirito 999-1776

SIGN HERE

DA FORM 2028-2  
 1 JUL 79

PREVIOUS EDITIONS ARE OBSOLETE.

PS--IF YOUR OUTFIT WANTS TO KNOW ABOUT YOUR RECOMMENDATION MAKE A CARBON COPY OF THIS AND GIVE IT TO YOUR HEADQUARTERS

TEAR ALONG PERFORATED LINE

RECOMMENDED CHANGES TO EQUIPMENT TECHNICAL PUBLICATIONS



THEN JOT DOWN THE DOPE ABOUT IT ON THIS FORM CAREFULLY TEAR IT OUT FOLD IT AND DROP IT IN THE MAIL

SOMETHING WRONG WITH THIS PUBLICATION?

FROM (PRINT YOUR UNIT'S COMPLETE ADDRESS)

DATE SENT

PUBLICATION NUMBER

TM 11-6665-245-12

PUBLICATION DATE

PUBLICATION TITLE

Radiac Set AN/PDR-56F

BE EXACT PIN-POINT WHERE IT IS

PAGE NO

PARA GRAPH

FIGURE NO

TABLE NO

IN THIS SPACE TELL WHAT IS WRONG AND WHAT SHOULD BE DONE ABOUT IT:

PRINTED NAME GRADE OR TITLE AND TELEPHONE NUMBER

SIGN HERE

DA FORM 2028-2 1 JUL 79

PREVIOUS EDITIONS ARE OBSOLETE

P.S. IF YOUR OUTFIT WANTS TO KNOW ABOUT YOUR RECOMMENDATION MAKE A CARBON COPY OF THIS AND GIVE IT TO YOUR HEADQUARTERS

FILL IN YOUR  
UNIT'S ADDRESS

FOLD BACK

DEPARTMENT OF THE ARMY

\_\_\_\_\_  
\_\_\_\_\_

OFFICIAL BUSINESS  
PENALTY FOR PRIVATE USE \$300

POSTAGE AND FEES PAID  
DEPARTMENT OF THE ARMY  
DOD 314



TEAR ALONG PERFORATED LINE

Commander  
US Army Communications and  
Electronics Materiel Readiness Command  
ATTN: DRSEL-ME-MQ  
Fort Monmouth, New Jersey 07703



# THE METRIC SYSTEM AND EQUIVALENTS

## WEIGHT MEASURE

1 Centimeter = 10 Millimeters = 0.01 Meters = 0.3937 Inches  
 1 Meter = 100 Centimeters = 1000 Millimeters = 39.37 Inches  
 1 Kilometer = 1000 Meters = 0.621 Miles

## WEIGHTS

1 Gram = 0.001 Kilograms = 1000 Milligrams = 0.035 Ounces  
 1 Kilogram = 1000 Grams = 2.2 lb.  
 1 Metric Ton = 1000 Kilograms = 1 Megagram = 1.1 Short Tons

## LIQUID MEASURE

1 Milliliter = 0.001 Liters = 0.0338 Fluid Ounces  
 1 Liter = 1000 Milliliters = 33.82 Fluid Ounces

## SQUARE MEASURE

1 Sq. Centimeter = 100 Sq. Millimeters = 0.155 Sq. Inches  
 1 Sq. Meter = 10,000 Sq. Centimeters = 10.76 Sq. Feet  
 1 Sq. Kilometer = 1,000,000 Sq. Meters = 0.386 Sq. Miles

## CUBIC MEASURE

1 Cu. Centimeter = 1000 Cu. Millimeters = 0.06 Cu. Inches  
 1 Cu. Meter = 1,000,000 Cu. Centimeters = 35.31 Cu. Feet

## TEMPERATURE

$5/9(^{\circ}\text{F} - 32) = ^{\circ}\text{C}$   
 212° Fahrenheit is equivalent to 100° Celsius  
 90° Fahrenheit is equivalent to 32.2° Celsius  
 32° Fahrenheit is equivalent to 0° Celsius  
 $9/5^{\circ}\text{C} + 32 = ^{\circ}\text{F}$

## APPROXIMATE CONVERSION FACTORS

TO CHANGE	TO	MULTIPLY BY
Inches	Centimeters	2.540
Feet	Meters	0.305
Yards	Meters	0.914
Miles	Kilometers	1.609
Square Inches	Square Centimeters	6.451
Square Feet	Square Meters	0.093
Square Yards	Square Meters	0.836
Square Miles	Square Kilometers	2.590
Acres	Square Hectometers	0.405
Cubic Feet	Cubic Meters	0.028
Cubic Yards	Cubic Meters	0.765
Fluid Ounces	Milliliters	29.573
its	Liters	0.473
arts	Liters	0.946
allons	Liters	3.785
Ounces	Grams	28.349
Pounds	Kilograms	0.454
Short Tons	Metric Tons	0.907
Pound-Feet	Newton-Meters	1.356
Pounds per Square Inch	Kilopascals	6.895
Miles per Gallon	Kilometers per Liter	0.425
Miles per Hour	Kilometers per Hour	1.609

TO CHANGE	TO	MULTIPLY BY
Centimeters	Inches	0.394
Meters	Feet	3.280
Meters	Yards	1.094
Kilometers	Miles	0.621
Square Centimeters	Square Inches	0.155
Square Meters	Square Feet	10.764
Square Meters	Square Yards	1.196
Square Kilometers	Square Miles	0.386
Square Hectometers	Acres	2.471
Cubic Meters	Cubic Feet	35.315
Cubic Meters	Cubic Yards	1.308
Milliliters	Fluid Ounces	0.034
Liters	Pints	2.113
Liters	Quarts	1.057
ers	Gallons	0.264
ms	Ounces	0.035
ograms	Pounds	2.205
Metric Tons	Short Tons	1.102
Newton-Meters	Pounds-Feet	0.738
Kilopascals	Pounds per Square Inch	0.145
ometers per Liter	Miles per Gallon	2.354
ometers per Hour	Miles per Hour	0.621



**PIN: 047703-002**